

HVAC-R

CATALOGUE

VOL 26.3

Panasonic

Haier

 **MITSUBISHI
HEAVY INDUSTRIES**

Rinnai

BLUEDIAMOND
CONDENSATE REMOVAL PUMPS

dixell

ebmpapst

 **Opteon**

GreenEarth 

Monkeytoe

 **CLIVET**

BERNZOMATIC

FANTECHTRADE 
MADE FOR TRADE



Contents

What's Inside	Page #
Heat Pumps	2-7
Refrigerants & Cylinders	8-9
Tools & Consumables	10
Pair Coils	11
Ducting	12
Base Mounts & Wall Brackets	13
Roof Mounts	14
Condensate Pumps	15
Chemicals	16
Temperature Controllers	17
Fans & Motors	18



Panasonic

Aero Series High Wall

Nanoe X air purification, Wi-Fi & wired control, Blue Fin condenser, reverse cycle. R32 refrigerant.

System	Heat	Cool
2.5kW Aero Kit	2.50 kW	3.20 kW
3.5kW Aero Kit	3.50 kW	4.00 kW
5.0kW Aero Kit	5.00 kW	6.00 kW
6.0kW Aero Kit	6.00 kW	7.20 kW
7.1kW Aero Kit	7.10 kW	8.00 kW
9.5kW Aero Kit	9.50 kW	10.3 kW



Panasonic

Developer Series R32 High Wall

Easy install, ECO + AI energy optimisation, dual timer, anti-bacterial filter, Blue Fin condenser. R32.

System	Heat	Cool
2.5kW Developer Kit	2.50 kW	3.0 kW
3.5kW Developer Kit	3.50 kW	4.0 kW
5.0kW Developer Kit	5.0 kW	6.0 kW
7.1kW Developer Kit	7.1 kW	8.0 kW
9.5kW Developer Kit	9.50 kW	10.3 kW

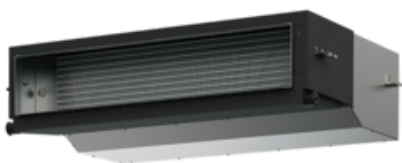

Panasonic

COMMERCIAL / WHOLE HOME

Whole-home climate control. Wi-Fi, zone control, weekly timer, R32. Ceiling concealed.

System	Heat	Cool
7.1 PE - Compact ODU	7.1 kW	7.1 kW
7.1 PE - Deluxe ODU	7.1 kW	8.0 kW
12.5 PE - Compact ODU	12.5 kW	12.5 kW
12.5 PE - Deluxe ODU	12.5 kW	14.0 kW
16.0 PE - Deluxe ODU	16.0 kW	18.0 kW
22.4 PE - Deluxe ODU 3PH	22.4 kW	25.0 kW

Also Available: Compact Cassette | Floor Console | Ceiling Suspended | Multi-Split Systems | VRF Systems | Parts & Accessories



Haier

Pinnacle Series

UV Protect LED Health mode, Coanda Plus airflow to 20m. SmarthQ, Google Home & Alexa.

600 Series QP

UV Protect, Coanda Plus airflow & self-clean. SmarthQ, Google Home & Alexa.



Haier

Multi Split Systems: Super Match

Heat or cool multiple rooms from one outdoor unit. Mix & match hi-wall, cassette, console or ducted indoor units – each room controlled independently. Wi-Fi & voice control. 5-year warranty.

- **Super Match Multi RC Outdoor Unit (R32)**
- **Wall Mounted Indoor – Pinnacle Series**
- **Wall Mounted Indoor – 600 Series QP**
- **4-Way Compact Cassette Indoor**
- **Slim Ducted Indoor (R32)**



Haier

High Static Ducted (R32)

Ducted Systems – Smart Power Whole-home heating & cooling hidden in the ceiling. Quiet, zoned, R32. SmarthQ app compatible.

System	Heat	Cool
AD100HN5FA-SET	11.5 kW	10.0 kW
AD125HN5FA-SET	14.0 kW	12.5 kW
AD140HP5FA-SET	15.0 kW	14.0 kW
AD160HP5FA-SET	17.0 kW	15.5 kW

Also Available: Single Room Hi-Wall | Multi Split Systems | Ducted Systems: Smart Power | MRV

Cooling only Also Available*



Avanti Series High Wall

Whisper-quiet, 3D auto airflow, weekly timer, reverse cycle. NZ's People's Choice Award winner 2025. R32.

System	Heat	Cool
SRK2OZSA-W	2.0 kW	2.7 kW
SRK25ZSA-W	2.5 kW	3.2 kW
SRK35ZSA-W	3.5 kW	3.7 kW
SRK5OZSA-W	5.0 kW	5.8 kW



Bronte Series High Wall

High-performance high wall for larger spaces. Allergen Clear System, 3D Auto Mode, long-reach airflow, Wi-Fi control. R32 refrigerant.

System	Heat	Cool
SRK63ZRA-W	6.3 kW	7.1 kW
SRK71ZRA-W	7.1 kW	8.0 kW
SRK80ZRA-W	8.0 kW	9.0 kW
SRK95ZRA-W	9.5 kW	10.3 kW
SRK100AVNAWZR	10.0 kW	11.2 kW

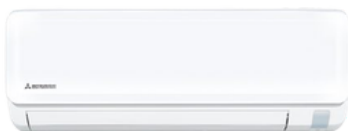

Ciara Series High Wall

Premium designer hi-wall. Built-in Wi-Fi, sleek low-profile, motion sensor energy saving, anti-allergen filtration. R32.

System	Heat	Cool
DXK09ZTLA-WF	2.5 kW	3.0 kW
DXK12ZTLA-WFJ	3.3 kW	3.8 kW
DXK18ZTLA-WF	5.0 kW	5.8 kW
DXK21ZTLA-WF	6.3 kW	7.1 kW
DXK24ZTLA-WF	7.1 kW	8.0 kW

Also Available: Compact Cassette | Floor Console | Slim Ducted | High Static Ducted | Multi-Split Systems | Parts & Accessories

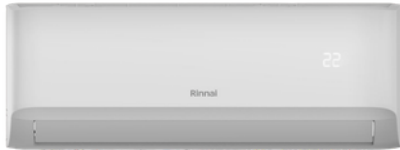

Rinnai

Pro Series 2 High Wall

Wi-Fi control, self-cleaning, quiet operation. Reverse cycle for modern residential spaces.

System	Heat	Cool
HSNRTX25	2.8 kW	2.5 kW
HSNRTX35	4.0 kW	3.5 kW
HSNRTX50	5.5 kW	5.0 kW
HSNRTX60	6.5 kW	6.0 kW
HSNRTX70	7.5 kW	7.0 kW
HSNRTX80	8.2 kW	7.6 kW
HSNRTX90	9.5 kW	9.0 kW

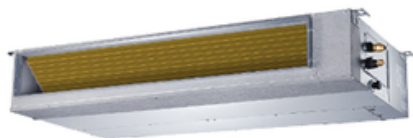

Rinnai

Pro Series Ducted

Ceiling-concealed ducted for whole-home comfort. Wi-Fi enabled, fast heating & cooling, clean finish.

System	Heat	Cool
DSNR07B1	7.5 kW	7.3 kW
DSNR09B1	10.0 kW	9.0 kW
DSNR15B1	14.5 kW	14.0 kW
DSNR18B1	18.0 kW	17.0 kW



Rinnai

Pro Series Multi Split

One outdoor unit, multiple indoor types. Flexible combinations for homes and multi-zone spaces.

- One outdoor unit, multiple rooms
- Flexible indoor unit combinations
- Ideal for homes and multi-zone spaces

Also Available: Floor Console | Compact Cassette | Slim Ducted | Ceiling Cassette | Single Split Systems | Parts & Accessories



Clivet AHU

Premium-spec Air Handling Units designed for high-profile projects and high-humidity applications. Modular designs offer the flexibility to add components as needed. AHU feature unitary structures that provide superior cold-bridge-free performance, reduced air leakage, and an elegant appearance.

- Thermal Bridging Class: TB1 ($0.75 \leq k < 1.00$)
- Thermal Transmittance Class: T2 ($0.5 < U \leq$
- Eurovent Certified Testing: Compliant with EN 1886



Clivet Eurovent & AHRI Certified Chillers

Clivet Eurovent & AHRI Certified Air-Cooled Chillers are available in a range of models, including Twin Section Liquid Chillers equipped with Inverter Screw Compressors and Multi-Stage Scroll Compressors.

These chillers are compatible with a variety of refrigerants, including R1234ze, R32, R410A, and R513A.



ActronAir Serene | R410A

Reliable wall-mounted heat pump using R410A refrigerant for proven, efficient performance. Ready-to-install units delivering quiet, consistent comfort for residential spaces.

System	Heat	Cool
WRC/RE-O26AS	2.85 kW	2.65 kW
WRC/RE-O35AS	3.75 kW	3.55 kW
WRE-O50AS	5.15 kW	5.0 kW
WRC/RE-O71AS	7.65 kW	7.1 kW
WRC/RE-O80AS	8.15 kW	8.0 kW

Also Available: (Clivet) Hydronic Systems | VRF Solutions | Ventilation Systems | Air Handling Units



REFRIGERANTS



R134A-13.6Kg

HFC refrigerant for automotive AC, commercial chillers and medium-temp refrigeration. Non-flammable, zero ODP.



R410A-11.3Kg

HFC blend for residential and commercial split system air conditioning. Non-flammable, zero ODP.



R407C-11.3Kg

HFC blend suited to AC and medium-temp refrigeration. Common retrofit refrigerant for R22 systems.



R407F-11.3Kg

HFC blend for medium and low-temp commercial refrigeration. Lower GWP alternative to R404A and R507.



R507-11.3Kg

Azeotropic HFC blend for low and medium-temp commercial and industrial refrigeration. Non-flammable.



R452A-11.35Kg

HFC/HFO blend for commercial and transport refrigeration. Non-flammable, lower GWP than R404A.



R449A-11.35Kg

HFC/HFO blend for low to medium-temp commercial refrigeration. Non-flammable, A1 safety rated.



R404A-10.9Kg

HFC blend for low and medium-temp commercial refrigeration systems. Non-flammable, zero ODP.



R454B-9.5Kg

Low GWP HFC/HFO blend for split systems and heat pumps. Mildly flammable, A2L safety rated.



R290

Natural propane refrigerant for small commercial and plug-in refrigeration. A3 rated – highly flammable.

R290-400g | R290-5.0 Kg



R32

Single-component HFC for residential split system air conditioning. A2L rated – mildly flammable.

R32-3.0Kg | R32-9.5Kg



R600A

Natural isobutane for domestic refrigerators and small plug-in units. A3 rated – highly flammable.

R600A - 3.0Kg | R600A - 6.5Kg



TOOLS & CONSUMABLES



Bernzomatic MAPP Gas Cylinder

Propylene-based fuel gas for brazing and soldering.
Compatible with standard brazing torches.

MAPP



Disposable Oxygen Cylinder

For Heavy Duty, Hi-temp usage
suitable for Bromic kit, 136GM

OXY



Recovery Gas Cylinder

Dot approved, 21.6 & 41.9 L bottles (20 & 40 kg), Y-Valve
liquid/vapour, 3/4" NPT opening accepts 80% Fill Capacity

RRC-14.3L

RRC-21.6L

RRC-41.9L



Adapter Valve for Gas Cylinder

Left-hand thread adapter for refrigerant gas
cylinders. Ensures secure, leak-free connection.

Left Hand Thread Adapter



Silver Brazing Rod

2.4 mm Diameter x 750 mm Length, silver, brown tip

P15-1Kg

P34-1KG

P45-1Kg



PAIR COILS



Glowbal Pair Coils

Pre-insulated copper pair coil for split system refrigerant lines. R410A & AS/NZS 1571 compliant. Supplied in 20 metre rolls. Suitable for residential and light commercial installations.

- AP-23** 1/4" x 3/8" Pipe Thickness
0.8 x 0.8mm Tube Wall Thickness - 20m
- AP-24** 1/4" x 1/2" Pipe Thickness
0.8 x 0.8mm Tube Wall Thickness - 20m
- AP-25** 1/4" x 5/8" Pipe Thickness
0.8 x 1.0mm Tube Wall Thickness - 20m
- AP-35** 3/8" x 5/8" Pipe Thickness
0.8 x 1.0mm Tube Wall Thickness - 20m
- AP-36** 3/8" x 3/4" Pipe Thickness
0.8 x 1.2mm Tube Wall Thickness - 20m



DUCTING

Toyo Ducting & Fittings 80MM

TD-80
Ducting
2M lengths



DC-80
Ducting
Cap



DL-80
Ducting
90Deg Elbow



DLW-80
Ducting
45Deg Elbow



DK-80
Ducting
Corner



DJ-80
Ducting
Joint



DT-80
Ducting
T-Joint



DF-80L
Ducting Long Flexi -
Joint



DF-80S
Ducting
Flexi - Joint



DE-80
Ducting
End Socket



DS-80
Ducting
Ceiling Cap



Toyo Ducting & Fittings 120MM

TD-120
Ducting
2M lengths



DC-120
Ducting
Cap



DL-120
Ducting
90Deg Elbow



DB-120
Ducting
Branch Joint



DK-120
Ducting
Corner



DJ-120
Ducting
Joint



DT-120
Ducting
T-Joint



URH-14
Drainpipe Double layer
14mm



DF-120
Ducting Long
Flexi - Joint



DR-120
Ducting
End Socket



DS-120
Ducting
Ceiling Cap





BASE MOUNTS & WALL BRACKETS

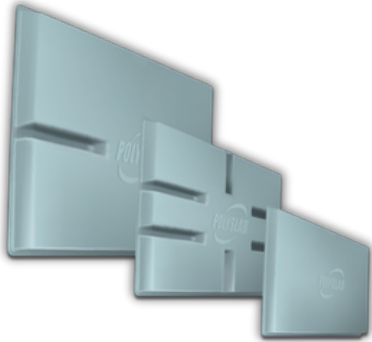

Polyslab HVAC-R Base Mounting

Durable and UV resistant, available in 2 sizes with weight load ratings of 270 kg and 160 kg

PS465 - 885x465x51



PVC Floor Support

Dimensions: 450mm, with stainless steel nuts & bolts

FSP2



Wall Brackets for A/C Units

Two Sizes, for A/C Condensers, Galvanised & Powder Coated, max weight 100 KG / 150 KG

HL-450 / HL-550



Stainless Steel Wall Brackets for A/C Units

Two Sizes, for A/C Condensers, Stainless Steel, max weight 100 KG / 150 KG

HL-450 SS / HL-550 SS



ROOF MOUNTS

Monkeytoe

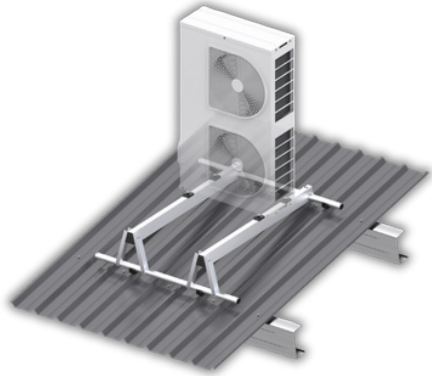

0-80KG

Monkeytoe Condensor Brackets

Roof mounts & wall brackets, adjustable aluminium

CS001.12.3

Light Weight Single Mount

- 1200mm Purlins
- 300mm Adjustable support

CS001.15.6

Light Weight Single Mount

- 1500mm Purlins,
- 600mm Adjustable support

CS001.18.6

Light Weight Single Mount

- 1800mm Purlins,
- 600mm Adjustable support

Monkeytoe

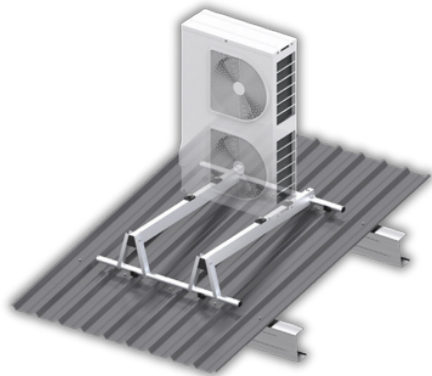

80-150 KG

Monkeytoe Condensor Brackets

Roof mounts & wall brackets, adjustable aluminium

CS001.12.3

Heavy Duty Single Mount

- 1200mm Purlins,
- 300mm Adjustable support

CS001H.15.6

Heavy Duty Single Mount

- 1500mm Purlins,
- 600mm Adjustable support

CS001H.18.6

Heavy Duty Single Mount

- 1800mm Purlins,
- 600mm Adjustable support



CONDENSATE PUMPS



Blue Diamond MicroBlue Condensate Pump

Flow: 5L/HR, Lift: 5M, Head: 2M

Microblue + Reservoir (HLA) X86-001

Ultra-compact self-priming condensate pump for mini-split systems up to 3.5kW. 17dB operation.



Blue Diamond MiniBlue Condensate Pump

Flow: 8L/HR, Lift: 5M, Head: 5M

Miniblue + Cooling Signal X87-504

Self-priming condensate pump for domestic and light commercial AC systems up to 8kW. 21dB operation.



Blue Diamond MaxiBlue Condensate Pump

Flow: 14L/HR, Lift: 8M, Head: 8M

Maxiblue + Reservoir (FSA) X87-701

Self-priming condensate pump for residential and commercial AC systems. Includes failsafe alarm.



CHEMICALS



Green Earth Coil Disinfectant

EPA registered, hospital-grade disinfectant for HVAC coils. Kills bacteria and mould on contact.

R-CDD/1 | R-CDD/5 | R-CDD/20 1L Sprayer, 5L/20L bottle



Green Earth Evaporator Coil Cleaner

Foaming cleaner for evaporator coils. Removes dirt, grease and biological buildup.

R-ECC/1 | R-ECC/5 | R-ECC/20 1L Sprayer, 5L/20L bottle



Green Earth Foam-Brite Alkaline Condenser Cleaner

Heavy-duty alkaline foam cleaner for condenser coils. Breaks down stubborn grease and carbon deposits.

R-FCC/1 | R-FCC/5 | R-FCC/20 1L Sprayer, 5L/20L bottle



Green Earth Air Filter Cleaner

Biodegradable cleaner for washable air filters. Removes dust, grease and airborne contaminants.

R-FCD/1 | R-FCD/5 | R-FCD/20 1L Sprayer, 5L/20L bottle



Green Earth Ice Machine Cleaner

Biodegradable cleaner for commercial ice machines. Removes scale, slime and mineral deposits.

R-IMC/1 | R-IMC/5 1L Sprayer, 5L bottle



Cal-Blue Micro Leak Detector

Freeze-protective, non-corrosive leak detection fluid. Instantly identifies refrigerant leaks on fittings and joints.

4182-24 0.95 Litre c/w Sprayer



CONTROLLERS & FANS

dixell



Dixell CX Series Digital Temp Controllers

Digital Temp Controller with "off cycle" defrost. Panel mount, dual humidity function, 230V AC. Fan relay, auxiliary alarm relay & Digi Input for selected models.

- XR20CX-B** Med temp | Off-cycle defrost
- XR30CX-B** Med temp | Defrost + alarm
- XR40CX-B** Med/Low temp | Defrost
- XR60CX-B** Low temp | Defrost + fan
- XR70CX-B** Low temp | Defrost + fan + alarm
- NG6P-1.5** Dixell Temp Sensor 1.5M NTC

Hidria



Hidria Axial Fans

Diameter 300mm / 350mm, 5 Blade
Nom. Watts (HS / LS): 80 / 145
Speed RPM: 1370 / 1400
3.5 / 6.0 KG Weight
220-240V / 50Hz

- R09R-3028A-4M-3509** (300mm)
- R11R-3530A-4M-3852** (350mm)

ebmpapst



EBM Axial Fans

Evaporator / Condenser fans
Low Noise Level, 4P & 1PH AC, with basket guard

- | | |
|-------------------------|-------|
| S4E300AS72CT-001 | 300mm |
| S4E350AN02CT-060 | 350mm |
| S4E400APO244-CTO | 400mm |
| S4E450AU0337-CTO | 450mm |
| S4E500AM0301-CTO | 500mm |
| S6E560AN0101 | 560mm |
| S6E630AN0101 | 630mm |



FANS & MOTORS

ebmpapst



EBM Q Series Fan Motors

Shaded pole motor, drop in replacement, refrigeration compatible

M4Q045BD0138-CTO	5W
M4Q045CA0138-CTO	7W
M4Q045CA0338A01-CTO	10W
M4Q045CF0138-CTO	16W
M4Q045DA0538-CTO	23W
M4Q045EA0138-CTO	25W
M4Q045EF0138-CTO	34W

FANTECHTRADE
MADE FOR TRADE



Fantech - JETLINE ECOWATT

HIGH PERFORMANCE IN-LINE DUCT MOUNTED FAN WITH EC MOTOR

JETLINE-100ECO	19 Watt
JETLINE-125ECO	40 Watt
JETLINE-150ECO	83 Watt
JETLINE-200ECO	125 Watt
JETLINE-250ECO	160 Watt
JETLINE-315ECO	215 Watt



Fantech - DOM

WALL / CEILING MOUNTED EXHAUST FAN

DOM-100C	14 Watt
DOM-125C	18 Watt
DOM-150C	23 Watt

Available in the 3 most popular spigot sizes; 100, 125 and 150mm.



GLOWBAL

Glowbal NZ Limited

11 Pavilion Dr, Airport Oaks, Auckland, New Zealand

+64 9 254 4500

sales@glowbal.co.nz | www.glowbal.co.nz