



GLOWBAL

HVAC-R

Product Catalogue

Panasonic

Rinnai

 **ActronAir**

ebmpapst

Monkeytoe

dixell®

GreenEarth 

POLYSLAB®

 **Opteon™**

Glowbal NZ Limited
11 Pavilion Dr, Airport Oaks, Auckland, New Zealand
sales@glowbal.co.nz | +64 9 254 4500

TABLE OF CONTENTS

	Page #
Heat Pumps & Accessories	2-6
Chemicals	7
Temperature Controllers	8
Axial Fans & Motors	9-11
Refrigerants, Cylinders & Accessories	12-16
Pair Coils	17
Ducting & Accessories	18
Base Mounts	19-20
Roof Mounts	21
Wall Brackets	22



CS/CU-Z25XKR-1
2.5kW

CS/CU-Z35XKR
3.5kW

CS/CU-Z20XKR
2.05kW

CS/CU-Z42XKR
4.2kW

CS/CU-Z50XKR
5.0kW

PANASONIC HIGH WALL R32 HEAT PUMPS



Panasonic AERO SERIES

NANOE X TECHNOLOGY • WIFI &
WIRED • BLUE FIN CONDENSER



CS/CU-Z50XKR-1
5.0kW

CS/CU-Z60XKR-1
6.0kW

CS/CU-Z71XKR
7.10kW

CS/CU-Z80XKR
8.0kW



HSNRP26

2.5 KW Cool / 2.7 KW Heat



HSNRP35

3.5 KW Cool / 4.0 KW Heat



HSNRP50

5 KW Cool / 5.2 KW Heat

**RINNAI HIGH WALL
HEAT PUMPS**

Rinnai PRO SERIES

PRO-PEL COIL PROTECTION • 3D AIRFLOW
TRIPLE HEALTH FILTER • WIFI CONTROL

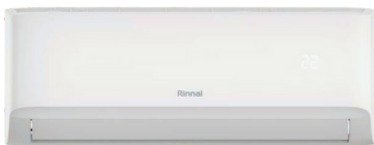

HSNRP60

6.0 KW Cool / 6.2 KW Heat

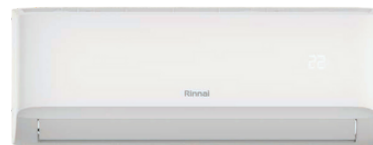

HSNRP70

7.0 KW Cool / 7.5 KW Heat

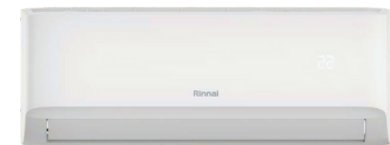

HSNRP80

8.0 KW Cool / 8.5 KW Heat



DSNR07B1

7.3 KW Cool / 7.5 KW Heat
Mid static - slim ducted



DSNR09B1

9.0 KW Cool / 10.0 KW Heat
Mid static - slim ducted

**RINNAI PRO SERIES
DUCTED HEAT PUMPS**



Rinnai 7.5 - 18KW RANGE

PRO-PEL COIL PROTECTION • WIFI CONTROL
ECO COOL • DAILY & WEEKLY TIMER • ZONING

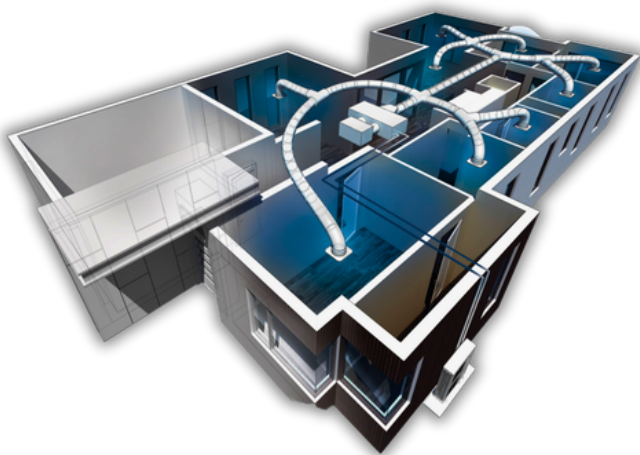

DSNR11B1

10.5 KW Cool / 11.5 KW Heat
High static - ducted

DSNR13B1

12.5 KW Cool / 13.0 KW Heat
High static - ducted

DSNR15B1

14.0 KW Cool / 14.5 KW Heat
High static - ducted

DSNR18B1

17.0 KW Cool / 18.0 KW Heat
High static - ducted



CRV2-14AS • ERV2-14AS

14.4 KW Cool / 15.4 KW Heat
Outdoor / Indoor



CRV3-17AS • ERV3-17AS

17.5 KW Cool / 19 KW Heat
Outdoor / Indoor



CRV4-19AS • ERV4-19AS

19 KW Cool / 20 KW Heat
Outdoor / Indoor

**ACTRONAIR ESP PLATINUM
DUCTED HEAT PUMPS**



TRU-INVERTER TECHNOLOGY • COATED COIL
PROTECTION • 1 PHASE • PIPE SIZE 3/8" X 3/4"



SRD131C • SRV131E

12.27 KW Cool / 12.16 KW Heat
Outdoor / Indoor



SRD151C • SRV151E

14.37 KW Cool / 15 KW Heat
Outdoor / Indoor



SRD191C • SRV191E

18.64 KW Cool / 18.52 KW Heat
Outdoor / Indoor

ACTRON CONTROLS SOFT STARTER

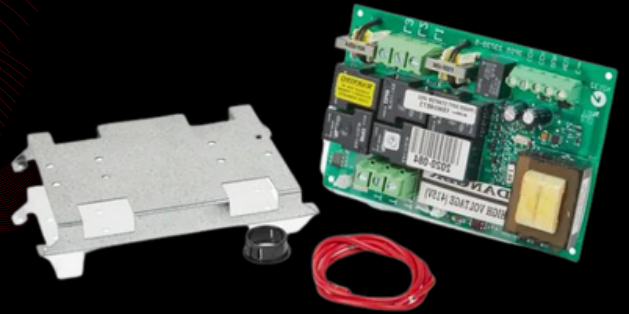

SPECS

PRODUCT CODE: 3PS5-001K

HANGING KIT SUIT FAN COIL UNIT

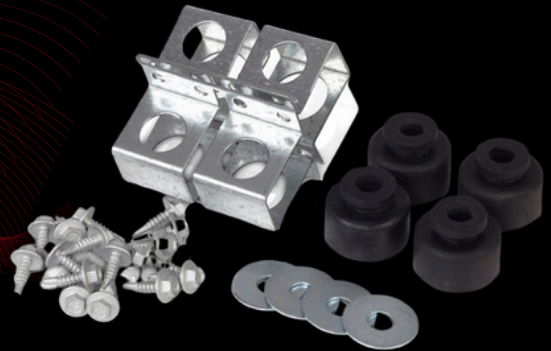

SPECS

PRODUCT CODE: AHKFC



R-CDD/1 • R-CDD/5

GreenEarth Coil Disinfectant
EPA Registered
Hospital Grade
1 Litre sprayer, 5 Litre bottle



R-ECC/1 • R-ECC/5

**GreenEarth Evaporator
Coil Cleaner**
Also available in 20 Litres:
R-ECC/20



R-FCC/1 • R-FCC/5

**GreenEarth Foam-Brite
Alkaline Condenser Cleaner**
Also available in 20 Litres:
R-FCC/20

CHEMICALS

GreenEarth 

**HVAC-R CLEANING &
MAINTENANCE**



R-FCD/1

GreenEarth Air Filter Cleaner
Biodegradable
1.0 Litre c/w sprayer



R-FCD/5

GreenEarth Air Filter Cleaner
Biodegradable
5.0 Litre bottle



4182-24

Cal-Blue Micro Leak Detector
Freeze Protective & non-Corrosive
0.95 Litre c/w sprayer



XR20CX-B

Medium Temp Controller
with "off cycle" defrost.
1 x NTC



XR30CX-B

Medium Temp Controller with
"off cycle" defrost and additional
configurable relay.
1 x NTC

DIXELL® TEMPERATURE CONTROLLERS

dixell CX SERIES

PANEL MOUNT • DUAL HUMIDITY
FUNCTION • 230V AC



XR40CX-B

Low Temp Controller with
electric defrost management.
2 x NTC



XR60CX-B

Low Temp Controller with
electric defrost, fan relay, Digi
Input.
2 x NTC



XR70CX-B

Low Temp Controller with
electric defrost, fan relay,
Auxiliary alarm relay, Digi Input.
2 x NTC



HIDRIA AXIAL FANS

Hidria**220-240V/50HZ**

SPECS

- DIAMETER: 300MM / 350MM
- 5 BLADE
- NOM. WATTS (HS / LS): 80 / 145
- SPEED RPM: 1370 / 1400
- 3.5 / 6.0 KG WEIGHT

PRODUCT CODES:

09R-3028A-4M-3509 [300MM]**R11R-3530A-4M-3852 [350MM]**

S4E300AS72CT-001

Condenser/Evaporator Fan
300mm 4P, 1PH AC fan
with basket guard

S4E350AN02CT-060

Condenser/Evaporator Fan
350mm 4P, 1PH AC fan
with basket guard

S4E400APO244-CT0

Condenser/Evaporator Fan
400mm 4P, 1PH AC fan
with basket guard

S4E450AU0337-CT0

Condenser/Evaporator Fan
450mm 4P, 1PH AC fan
with basket guard

EBM AXIAL FANS



- LOW NOISE LEVEL
- 4P & 1PH AC
- WITH BASKET GUARD

S4E500AM0301-CT0

Condenser/Evaporator Fan
500mm 4P, 1PH AC fan
with basket guard

S6E560AN0101

Condenser/Evaporator Fan
560mm 4P, 1PH AC fan
with basket guard

S6E630AN0101

Condenser/Evaporator Fan
630mm 4P, 1PH AC fan
with basket guard

M4Q045BD0138-CTO

EBM Q Series
refrigeration fan motor
5 Watt

M4Q045CA0138-CTO

EBM Q Series
refrigeration fan motor
7 Watt

M4Q045CA0338A01-CTO

EBM Q Series
refrigeration fan motor
10 Watt

M4Q045CF0138-CTO

EBM Q Series
refrigeration fan motor
16 Watt

EBM Q SERIES FAN MOTORS



- SHADED POLE MOTOR
- DROP IN REPLACEMENT
- REFRIGERATION COMPATIBLE

M4Q045DA0538-CTO

EBM Q Series
refrigeration fan motor
23 Watt

M4Q045EA0138-CTO

EBM Q Series
refrigeration fan motor
25 Watt

M4Q045EF0138-CTO

EBM Q Series
refrigeration fan motor
34 Watt

HI-PRESSURE NITROGEN PISTON REGULATOR

 **GLOWBAL VICTOR STYLE**

SPECS

- T SCREW ADJUSTMENT & SIDE ENTRY
- EXTERNAL SAFETY RELIEF VALVE
- FORGED BRASS BODY & BONNET
- SINTERED METAL INLET FILTER
- NO SOLDERED JOINTS
- NET WEIGHT 1.5KG/EA
- SINGLE STAGE

PRODUCT CODE: DW-P4-203-50M

R134A-13.6

R410A-11.3

R407C-11.3

R404A-10.9

R407F-11.3

REFRIGERANT GAS CYLINDERS



- FOR HVAC-R EQUIPMENT
- VARIOUS APPLICATIONS

R507-11.3

R449A-11.35

R32-3.0

R600A-3.0

ADAPTER VALVE

R449A / XP40 REFRIGERANT GAS



SPECS

- 11.35 KG NET WEIGHT
 - SUITABLE REPLACEMENT FOR R404A
 - DISPOSABLE CLYINDER
- PRODUCT CODE: R449A-11.35**



R454B/ XL41 REFRIGERANT GAS



SPECS

- 9.5 KG NET WEIGHT
 - SUITABLE REPLACEMENT FOR R410A
 - DISPOSABLE CLYINDER
- PRODUCT CODE: R454B-9.5**



R452A / XP44 REFRIGERANT GAS



SPECS

- 11.35KG NET WEIGHT
 - SUITABLE REPLACEMENT FOR R404A
 - DISPOSABLE CLYINDER
- PRODUCT CODE: R452A-11.35**



REFRIGERANT GAS RECOVERY CYLINDERS

 **GLOWBAL DOT APPROVED**

SPECS

- 21.6/41.9 LITRE BOTTLES [20 & 40KG]
 - Y-VALVE FOR LIQUID/VAPOR
 - 3/4" NPT OPENING ACCEPTS 80%
- PRODUCT CODES: RRC-21.6L / RRC-41.9L**

MAPP GAS CYLINDER

 **GLOWBAL**

SPECS

- PROPLYENE
- SUITABLE FOR BRAZING TORCH
- 400GM

PRODUCT CODE: MAPP

DISPOSABLE OXYGEN CYLINDER



SPECS

- FOR HEAVY DUTY, HI-TEMP USAGE
- SUITABLE FOR BROMIC KIT
- 136GM

PRODUCT CODE: OXY

SILVER BRAZING ROD



SPECS

- 2.4MM DIAMETER X 750MM LONG
- 15% SILVER
- BROWN TIP

PRODUCT CODE: P15-1KG



AP-23

Copper Pipe Thickness:
1/4" x 3/8"
Tube Wall Thickness:
0.8 x 0.8mm



AP-24

Copper Pipe Thickness:
1/4" x 1/2"
Tube Wall Thickness:
0.8 x 0.8mm



PAIR COILS



Fire Rated
to EU Stds



Pre-Insulated
Copper 20M



R410A
Compliant



AS/NZS 1571
Compliant



AP-25

Copper Pipe Thickness
1/4" x 5/8"
Tube Wall Thickness:
0.8 x 1.0mm













AP-35

Copper Pipe Thickness
3/8" x 5/8"
Tube Wall Thickness:
0.8 x 1.0mm



AP-36

Copper Pipe Thickness
3/8" x 3/4"
Tube Wall Thickness:
0.8 x 1.2mm

TD-80 Ducting 2M lengths 	DC-80 Ducting Cap 	DL-80 Ducting 90Deg Elbow 	DLW-80 Ducting 45Deg Elbow 
DK-80 Ducting Corner 	DJ-80 Ducting Joint 	DT-80 Ducting T-Joint 	DF-80L Ducting Long Flexi - Joint 
DF-80S Ducting Flexi - Joint 	DE-80 Ducting End Socket 	DS-80 Ducting Ceiling Cap 	













& HVAC FITTINGS

DUCTING



120MM DUCTING

TD-120 Ducting 2M lengths 	DC-120 Ducting Cap 	DL-120 Ducting 90Deg Elbow 	DB-120 Ducting Branch Joint 
DK-120 Ducting Corner 	DJ-120 Ducting Joint 	DT-120 Ducting T-Joint 	URH-14 Drainpipe Double layer 14mm 
DF-120 Ducting Long Flexi - Joint 	DR-120 Ducting End Socket 	DS-120 Ducting Ceiling Cap 	

POLYSLAB HVAC-R BASE MOUNTING

POLYSLAB UV RESISTANT

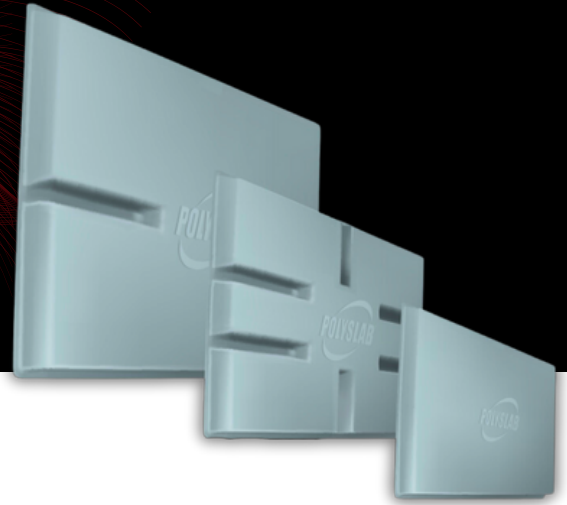

SPECS

- DIAMETER 465 X 885 X 51MM [MEDIUM]
- 160KG LOAD RATING
- ALSO AVAILABLE IN SMALL / LARGE

PRODUCT CODES:
PS465 [MEDIUM]

PVC FLOOR SUPPORT

 **GLOWBAL**



SPECS

- DIAMETER 450MM
- WITH STAINLESS STEEL NUTS & BOLTS

PRODUCT CODES:
FSP2

TUFFSLAB HVAC BASE MOUNT

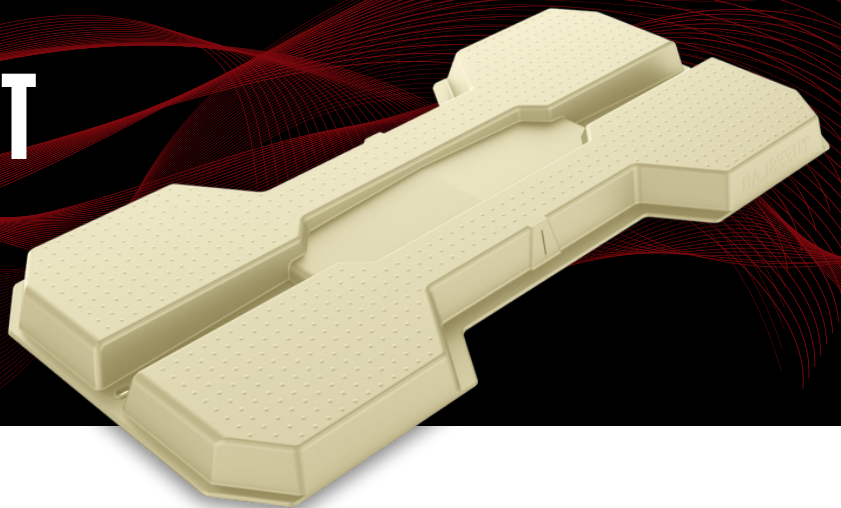

SPECS

- DIMENSION: 900 X 430 MM
- 100% RECYCLED PLASTIC
- VENTILATION POINTS
- FASTENING HOLES
- 160KG LOAD RATING
- UV STABILISED
- MOISTURE RUNOFF
- SUPERIOR NESTABILITY

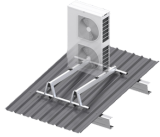

CS001.12.3

Light Weight Single Mount
300mm Adjustable Support
1200mm Purlins
0-80KGS

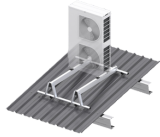

CS001.15.6

Light Weight Single Mount
600mm Adjustable Support
1500mm Purlins
0-80KGS

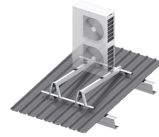

CS001.18.6

Light Weight Single Mount
600mm Adjustable Support
1800mm Purlins
0-80KGS

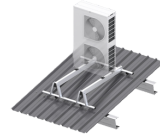

CS001H.12.3

Heavy Duty Single Mount
300mm Adjustable Support
1200mm Purlins
80-150KGS

CONDENSER MOUNTS & BRACKETS

Monkeytee

- ROOF MOUNTS & WALL BRACKETS
- ADJUSTABLE ALUMINIUM
- LIGHT & HEAVY WEIGHT

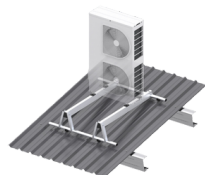
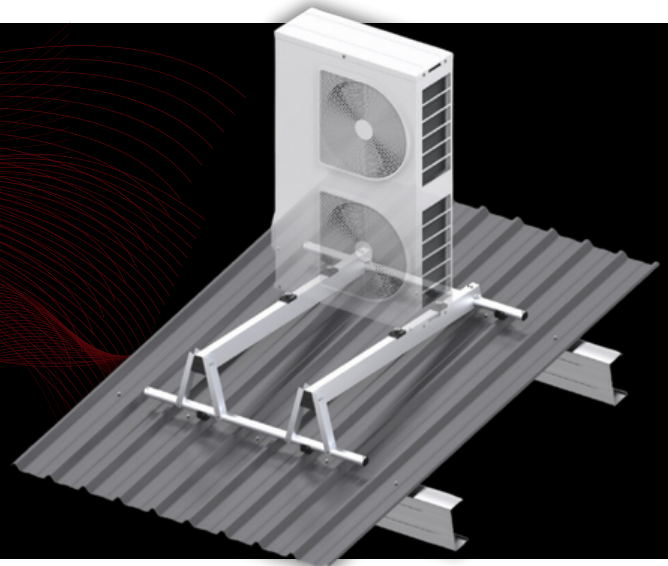

CS001H.15.6

Heavy Duty Single Mount
600mm Adjustable Support
1500mm Purlins
80-150KGS

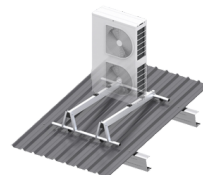

CS001H.18.6

Heavy Duty Single Mount
600mm Adjustable Support
1800mm Purlins
80-150KGS

WALL BRACKETS FOR A/C UNITS

 **GLOWBAL TWO SIZES**



SPECS

- FOR A/C CONDENSORS
- GALV & POWDER COATED
- MAX WEIGHT 100KG / 150KG

**PRODUCT CODES:
HL-450 / HL-550**