



ECOLIFE

LED DOWNLIGHT

LED HALO

High Lumen and Low Maintenance

Triac Dimmable and IC-F rated

IP54 and IK06 rated downlight

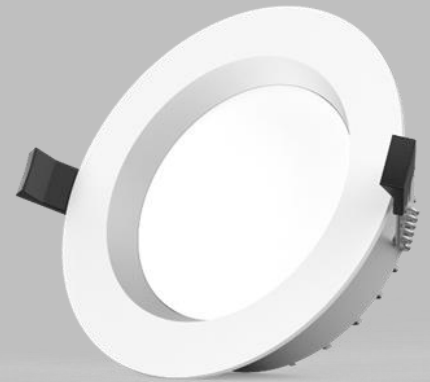

3000K

4000K

5700K

APPLICATIONS

- Office
- Shops
- Supermarket
- Workshop
- Hotels
- Public Areas

FEATURES

- Easy to install
- Robust Aluminium Die cast body
- System Efficacy 100lm/W
- IK 06 & IP54
- Operating Temperature -20° to 45° C
- Triac Dimmable
- IC-F Rating: Abutted & Covered



SUPPLIED BY



GLOWBAL

www.glowbal.co.nz

Phone: +64 9 254 4500 | Fax: +64 9 275 8183



LED HALO

Product Dimensions

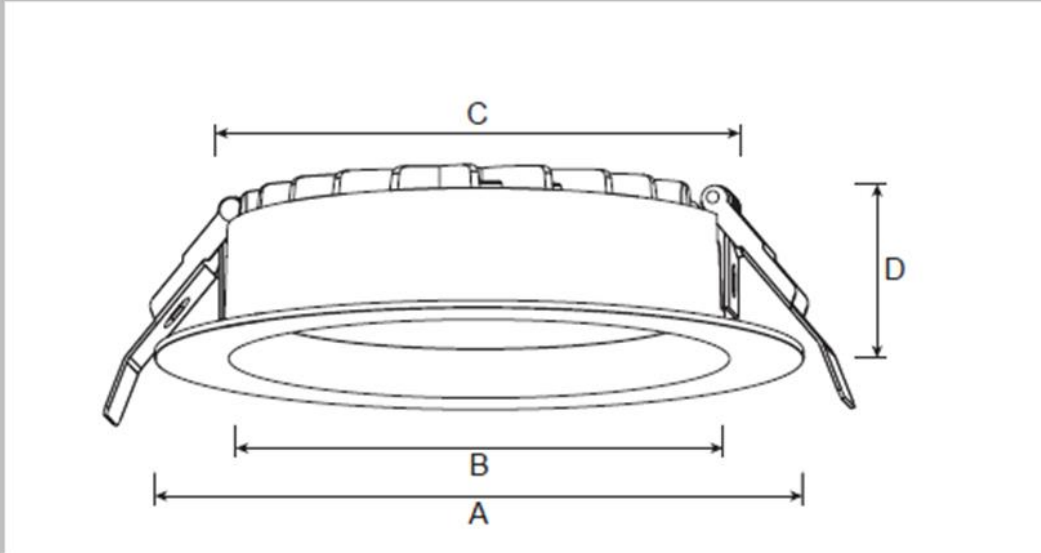

| A (mm) | B (mm) | C (mm) | D (mm) | Size (mm) | Product Weight (Kg) |
|--------|--------|--------|--------|-----------|---------------------|
| 145 | 104 | 118 | 45 | Ø145*45 | 0.46 |

Technical Data Sheet

| SKU | Model | Power (W) | Luminous Flux | Colour Temperature (K) |
|-------|----------|-----------|---------------|------------------------|
| 22130 | LED HALO | 15 | 1380-1580 | 3000/4000/5700 |

